

BACK HOE

















SALIENT FEATURES

- Strong boom & stick
- Easy attachable and detachable
- Sturdy hydraulic system
- Adjustable seat

BACK HOE

Backhoe is used for various purposes like digging, loading, backfilling, trenching, and provides the maximum power and performance in all types of soils. Solis backhoe is easy to use and is very versatile. It can be quickly attached and detached from tractor.

TECHNICAL SPECIFICATIONS

 Model Name	 Loading Height (A) (cm)	 Digging Depth (B) (cm)	 Max Height (C) (cm)	 Digging width (D) (cm)	 Max width (cm)	 Breakout force (kg)	 Rotation angle (degree)	 Pump capacity (L/m)	 Ground Clearance (mm)	 Pressure (bar)	 Bucket Size included	 3 Point Hitch	 Tractor Power (HP)	 Weight with standard bucket (kg)
SLBH 180	150	180	225	247	225	1500	180	18	300	180	Series 1 / 30cm	Cat I	20-30	375



STRONG BOOM & STICK



EASY ATTACHABLE AND DETACHABLE



STURDY HYDRAULIC SYSTEM



ADJUSTABLE SEAT

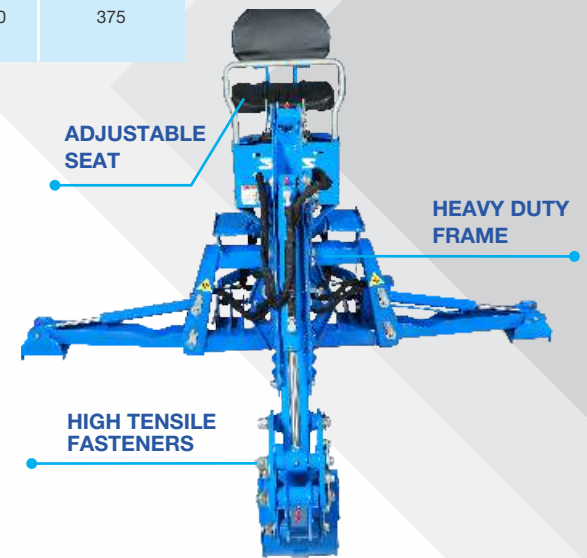

INTERNATIONAL TRACTORS LIMITED

International Business Office: Teri School of Advanced Studies, Plot No.10, Institutional Area, Vasant Kunj, New Delhi-110070 (India)
Phone: +91 11 66 45 5200 | **Work:** Jalandhar Road, Hoshiarpur - 146022, Punjab (India) | **Phone:** +91-01882-522220/ 522221
Fax:+91- 01882-522222 | **Email:** info@solis.com | **URL:** www.solistractors.com

Auth. Dealer